

# Application of selected multi-axial fatigue criteria on the results of non-proportional fatigue experiments

F. Fojtík<sup>a,\*</sup>, J. Fuxa<sup>a</sup>, Z. Poruba<sup>a</sup>

<sup>a</sup>Faculty of Mechanical Engineering, VŠB – Technical University of Ostrava, 17 listopadu 15, 708 33 Ostrava-Poruba, Czech Republic

Received 23 August 2010; received in revised form 13 December 2010

---

## Abstract

The contribution describes the experimental results obtained from the combined loading of the specimens in the field of high-cycle fatigue. Those specimens were manufactured from common construction steel 11523.1, melt T31052.

The following experiments were performed: The first set of the specimen was loaded by the alternating bending amplitude. The second set was loaded by the amplitude of the bending in combination with constant inner overpressure. The results were evaluated by the conjugated strength criterion and another generally used multi-axial fatigue criteria. The stress-strain analysis of the specimens by FEM was performed to determine parameters (constants) of particular strength criteria.

© 2010 University of West Bohemia. All rights reserved.

*Keywords:* combined loading, experiment, high-cycle fatigue, multi-axial analysis

---

## 1. Introduction

Although the material failure phenomenon in the conditions of multi-axial fatigue is investigated for many years by world-known research institutes, the reliable mathematical description making possible to describe this boundary state was not introduced yet. Hence, it is still necessary to perform expensive prototype verification. The evidence of this fact is number of laboratories especially in aircraft and automotive industry. We bring another build-stone into the mosaic of this interesting technical field in this contribution.

Number of fatigue experiments using both the reconstructed and new proposed devices [1], were performed at the Department of Mechanics of Material, VSB-TU Ostrava. The aim was to verify the ability of the conjugated strength criterion [2] proposed at our department and to use it for coupling of static and fatigue multi-axial strength criterion.

Our contribution describes certain findings obtained from four different types of mechanical material loading. The experiments were performed on hollow specimens manufactured from the steel 11523.1. The experimental data obtained at the fatigue limit were judged primarily, i.e. for specimens which were not damaged after  $10^7$  cycles. The below presented methodology is made for this lifetime. The experimental data obtained for given combinations of loading even for the fields of lifetime strength are mentioned in this contribution as well. Those experiments were performed with the testing frequency of 25 Hz. The obtained data were used to determine the constants of conjugated strength criterion whose application can be suitable even for prediction of boundary cycle number in the field of lifetime strength [3].

---

\*Corresponding author. Tel.: +420 597 323 292, e-mail: frantisek.fojtik@vsb.cz.

## 2. Experimental material

The experiments were performed on the hollow specimens (fig. 1) manufactured from low carbon steel CSN 411523.1 melting T31052. Those specimens were polished on the outer diameter. The chemical content and basic mechanical properties of this material are summarized in table 1 and table 2.

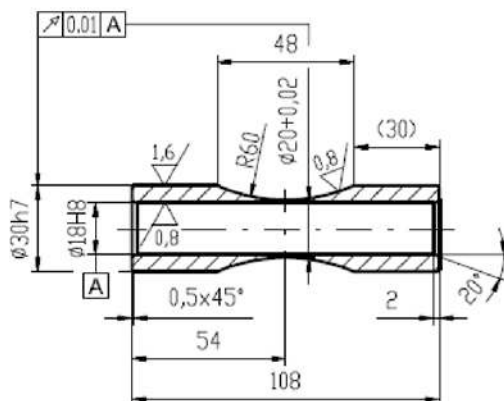

Fig. 1. Testing specimen

Table 1. Chemical properties of the specimen material

C	Mn	Si	P	S	Cu
%	%	%	%	%	%
0.18	1.38	0.4	0.018	0.006	0.05

Table 2. Mechanical properties of specimen material

Ultimate tensile strength [MPa]	Tensile yield stress [MPa]	Elongation at fracture [%]	Reduction of area at fracture [%]
560	400	31.1	74.0

The following material parameters were experimentally found out for the setting of below mentioned fatigue criteria.

tensile modulus:  $E = 2.06 \cdot 10^5$  MPa,

Poisson's ratio:  $\mu = 0.3$ .

Other material parameters determined via experiment for given material and melting which are necessary for setting of given fatigue criteria.

fatigue limit in fully reversed torsion:  $t_{-1} = 160$  MPa,

fatigue limit in fully reversed plane bending:  $f_{-1} = 311$  MPa,

fatigue limit in repeated bending:  $f_0 = 380$  MPa,

tensile true fracture strength:  $\sigma_f = 979.2$  MPa,

torsion true fracture strength:  $\tau_f = 516.6$  MPa.

### 3. Used multiaxial fatigue methods

The following generally used fatigue strength criteria were used for the analysis of performed experiments. The results obtained in experimental way for given loading combination on the fatigue limit will be judged by those criteria.

#### 3.1. Crossland method

Crossland published his results in the 50<sup>th</sup> of previous century. His criterion uses the square root from the second invariant of stress tensor. This invariant is determined from the stress amplitude. Another term added to the equation is the hydrostatic stress calculated from maximal stress values [4]

$$a_C \cdot \left( \sqrt{J_2} \right)_a + b_C \cdot \sigma_{H,\max} \leq f_{-1}, \quad (1)$$

where coefficients  $a_C$  and  $b_C$  are defined as:

$$\begin{aligned} a_C &= \frac{f_{-1}}{t_{-1}}, \\ b_C &= \left( 3 - \frac{f_{-1}}{t_{-1}} \right), \end{aligned} \quad (2)$$

other parameters in the equation are:

$J_2$  second invariant of stress tensor deviator,  $f_{-1}$  fatigue limit in fully reversed axial loading (in tension, in bending or in rotating bending),  $\sigma_{H,\max}$  maximum value of hydrostatic stress during load history,  $t_{-1}$  fatigue limit in fully reversed torsion.

#### 3.2. Sines method

Sines published his results in the same period as Crossland. The formulation of both criteria as similar, they differ in the determination of hydrostatic stress. Sines calculate this stress from mean stress values [5]

$$a_S \cdot \left( \sqrt{J_2} \right)_a + b_S \cdot \sigma_{H,m} \leq f_{-1}, \quad (3)$$

where coefficients  $a_S$  and  $b_S$  are defined as:

$$\begin{aligned} a_S &= \frac{f_{-1}}{t_{-1}}, \\ b_S &= 6 \cdot \frac{f_{-1}}{f_0} - \sqrt{3} \cdot \frac{f_{-1}}{t_{-1}}, \end{aligned} \quad (4)$$

where  $f_0$  is fatigue limit in repeated bending,  $\sigma_{H,m}$  mean value of hydrostatic stress during load history, other parameters in the equation are defined as in the case of Crossland Method.

#### 3.3. Dang Van method

This criterion belongs to the mesoscopic criteria. The mesoscopic criteria have their common point in an assumption that not the apparent macroscopic quantities, but their mesoscopic counterpart related to the least homogenous agglomerates of grains should be checked for fatigue evaluation. Dang Van initiated the solution and presented a way of transforming the mesoscopic quantities towards macroscopic stresses [9]. Dang Van criterion can be written for the lifetime at the fatigue limit in following way:

$$a_{DV} \cdot C_a + b_{DV} \cdot \sigma_{H,\max} \leq f_{-1}, \quad (5)$$

where

$$\begin{aligned} a_{DV} &= \frac{f_{-1}}{t_{-1}}, \\ b_{DV} &= 3 - \frac{3}{2} \cdot \frac{f_{-1}}{t_{-1}}, \end{aligned}$$

where  $C_a$  is shear stress amplitude on an examined plane,  $\sigma_{H,\max}$  maximum value of hydrostatic stress during load history.

### 3.4. McDiarmid method (McD)

This criterion is widely used. On the base of number of experiments McDiarmid proposed the following form of the criterion:

$$\frac{f_{-1}}{t_{AB}} \cdot C_a + \frac{f_{-1}}{2 \cdot S_u} \cdot N_{\max} \leq f_{-1}, \quad (6)$$

where  $C_a$  is shear stress amplitude on an examined plane,  $f_{-1}$  is fatigue limit in fully reversed axial loading,  $N_{\max}$  is maximum normal stress on the plane examined,  $S_u$  is tensile strength,  $t_{AB}$  is fatigue limit in fully reversed torsion with crack in  $A$  or  $B$  system. The crack parallel with the surface is typical for the type  $A$ . The crack leading inside down from the surface is typical for type  $B$  [6]. The following equivalence was used for the solution:  $t_{AB} = t_{-1}$ .

### 3.5. Papadopoulos method (Papad)

The Papadopoulos method is based on the Dang Van Criterion. However this method integrates the input variables in all planes. The method can be found in following form [7]:

$$\sqrt{a_p \cdot (T_a^2)} + b_p \cdot \sigma_{H,\max} \leq f_{-1}, \quad (7)$$

where

$$a_p = 5 \cdot \kappa^2, \quad b_p = 3 - \sqrt{3} \cdot \kappa, \quad \kappa = \frac{f_{-1}}{t_{-1}},$$

where  $T_a$  is resolved shear stress ( $a$  projection of shear stress into a given direction),  $K$  is ratio of fatigue limits.

### 3.6. Papuga PCr method

Papuga proposed the criterion on the base of long-term studies of multiaxial fatigue criteria in following form (7) [8]. According to his research embodies this criterion the most accurate results for wide range of materials

$$\sqrt{a_C \cdot C_a^2 + b_C \cdot \left( N_a + \frac{t_{-1}}{f_0} \cdot N_m \right)} \leq f_{-1}. \quad (8)$$

It is valid for following ratio of fatigue limits:

$$\begin{aligned} \kappa &< \sqrt{\frac{4}{3}} \cong 1.155, \text{ is:} \\ a_C &= \frac{\kappa^2}{2} + \frac{\sqrt{\kappa^4 - \kappa^2}}{2}, \quad b_C = f_{-1} \\ \kappa &\geq \sqrt{\frac{4}{3}} \cong 1.155, \text{ is:} \\ a_C &= \left( \frac{4 \cdot \kappa^2}{4 + \kappa^2} \right), \quad b_C = \frac{8 \cdot f_{-1} \cdot \kappa^2 \cdot (4 - \kappa^2)}{(4 + \kappa^2)^2}. \end{aligned}$$

### 3.7. Mataka method

The Mataka criterion is the critical plane criterion of the following form [7, 9]

$$a_M \cdot C_a + b_M \cdot N_{\max} \leq f_{-1}, \quad (9)$$

where

$$\begin{aligned} a_M &= \frac{f_{-1}}{t_{-1}}, \\ b_M &= 2 - \frac{f_{-1}}{t_{-1}}. \end{aligned}$$

Here  $C_a$  is shear stress amplitude on the plane experiencing maximum shear stress range,  $N_{\max}$  maximum normal stress on the same plane.

### 3.8. Conjugated strength criterion

This criterion was proposed by Fuxa [2]. For the crack initiation in  $N$ -th cycle it can be written in following form:

$$\frac{f_{-1} \cdot (A_N - B_N \cdot \sigma_R)}{S_\sigma} \leq f_{-1}, \quad (10)$$

where  $S_\sigma$  marks the stress intensity and is defined as:

$$S_\sigma = \frac{1}{\sqrt{2}} \cdot [(\sigma_1 - \sigma_2)^2 + (\sigma_2 - \sigma_3)^2 + (\sigma_3 - \sigma_1)^2]^{\frac{1}{2}}, \quad (11)$$

$\sigma_R$  is the reference stress value producing the identical value as the octaedric normal stress and can be written as:

$$\sigma_R = (\sigma_1 + \sigma_2 + \sigma_3) / 3, \quad (12)$$

where  $\sigma_1, \sigma_2, \sigma_3$  are the principal stresses. The value  $A_N$  can be considered as dependent on the cycle number  $N$  and is written as:

$$A_N = (A_O + A_C) / 2 + (A_O - A_C) / 2 \cdot \cos \{ \pi \cdot [\log(4 \cdot N) / \log(4 \cdot N_C)]^a \}. \quad (13)$$

$A_O$  is the constant of the static reference strength criterion and can be determined based on the torsion test:

$$A_O = 3^{1/2} \cdot \tau_f. \quad (14)$$

$A_C$  the stress intensity at the fatigue limit in torsion,  $N_C$  number of cycles at the fatigue limit,  $a$  material constant,  $B_N$  is the constant equal to:

$$B_N = 3 \cdot \left( \sqrt{3} \cdot \tau_f / \sigma_f - 1 \right), \quad (15)$$

where  $\sigma_f$  is the value of true fracture strength in tension and  $\tau_f$  is the value of true fracture strength in torsion.

### 3.9. Fatigue index error

All mentioned criteria according to the results from (1, 3, 5, 6, 7, 8, 9, 10) judge if the component is able to transfer the infinity of loading cycles. Evaluate of those criteria the fatigue index error  $\Delta FI$  is used. It shows the rate of deviation from the ideal equilibrium of the left and right hand sides of mentioned criterion relations [9]

$$\Delta FI = \frac{LHS(load) - f_{-1}}{f_{-1}} \cdot 100 \%, \quad (16)$$

where LHS is the left hand side of the equation. The relation  $LHS(load) \leq f_{-1}$  has to be fulfilled. If LHS is greater, the component may fail.

## 4. First experiment — alternating bending

The first set of specimens was loaded by the nominal amplitude of the bending. In the case of first specimen the proper amplitude was set and the number of cycles until failure was registered. In case of other specimens, the amplitude was stepwise reduced until the fatigue limit —  $10^7$  cycles — was reached. The experiments were performed at the frequency 25 Hz. The experimental results are summarized in table 3 where  $\sigma_a$  is the stress amplitude in bending and  $\sigma_p$  is the constant inner overpressure. The resulting stress was obtained via stress/strain analysis using FEM in the software ANSYS. The limit stress intensity leading to the crack initiation in  $N_f$  cycles is depicted in fig. 2. It is calculated from obtained stress values.

Table 3. Experimental results for alternating bending

Nr.	$\sigma_a$ [MPa]	$\sigma_p$ [MPa]	$N_f$ [-]	Notes
1	376.9	0	89 700	
2	352.4	0	196 635	
3	336.8	0	214 430	
4	324.8	0	1 262 300	
5	319.0	0	5 037 000	
6	311.0	0	11 631 000	No crack generated

## 5. Second experiment — alternating bending and inner overpressure

The second set of specimens was loaded in every series by the nominal amplitude of the bending moment and constant inner overpressure until the crack initiation. The loading of the specimen is described in fig. 3. This amplitude was gradually decreased until the value when was the

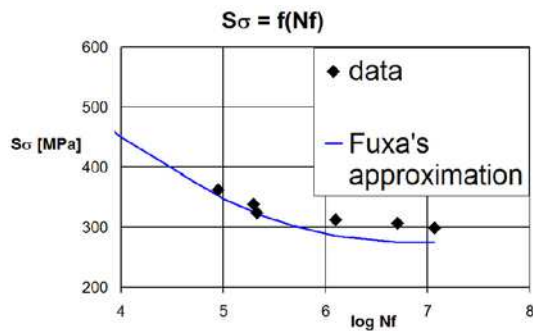

Fig. 2. S-N curve for alternating bending

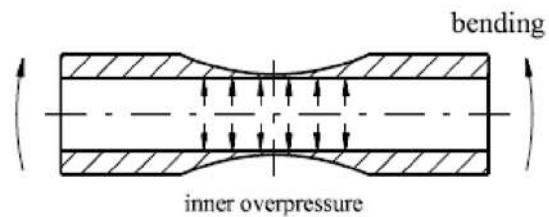

Fig. 3. The loading of the specimen

specimen able to endure  $10^7$  of cycles. The experiments were performed at the frequency 25 Hz again. The experimental results are summarized in table 4.

The dominant components of the stress tensor for both stress states are in table 4. The other components of the stress tensor are significantly smaller and were neglected in the analysis.

It was determined in the critical spot of the specimen using the FEM analysis in software ANSYS.

Table 4. Experimental results for alternating bending and inner overpressure

Nr.	$\sigma_a$ [MPa]	$\sigma_p$ [MPa]	$N_f$ [-]	Notes
1	339.1	203.8	81 900	
2	314.8	205.5	172 200	
3	301.7	207.3	299 000	
4	296.0	203.8	813 000	
5	286.7	202.0	10 200 000	No crack generated
6	293.7	312.9	266 800	
7	281.8	312.9	894 400	
8	274.4	312.9	11 050 000	No crack generated

## 6. Experimental results analysis

The obtained experimental results from all described experiments were used for the analysis of above mentioned fatigue stress criteria. Only those experimental results were analyzed where the failure was not reached until  $10^7$  cycles. The software Pragtic was used for the analysis. This software is free accessible at <http://www.pragtic.com> [9]. It contains all mentioned criteria with the exception of Conjugated stress criterion which was proposed at the authors' laboratory. The program in Microsoft Office Excel was created for the analysis of this criterion. The results of this study are depicted in table 5.

Table 5. Experimental results analysis

Nr.	$\sigma_a$ [MPa]	$\sigma_p$ [MPa]	$\Delta FI$ (%)							
			Sines	Crossland	Dang Van	McD	Papad	Papuga PCr	Matake	Fuxa
1	311.0	0.0	12.2	0.0	0.0	11.1	0.0	0.0	0.0	2.8
2	286.7	202.0	36.8	-15.8	-6.0	11.3	-15.8	-6.8	-6.0	18.7
3	274.4	312.9	50.7	-24.1	-8.9	11.9	-24.1	-10.2	-8.9	4.4

## 7. Conclusion

The common used multi-axial strength criteria (see above) and the conjugated strength criterion [2] proposed by the authors of this contribution with the aim of coupling the static and fatigue multi-axial criterion, have been described in this contribution.

The three sets of experiments have been performed on the hollow, thin-walled specimen made of steel 11523.1. The different stress states were generated in the specimens during the loading: alternating bending, alternating bending with constant inner overpressure with two levels. The results of the experiments have been applied to verify the mentioned strength criteria.

According to the values of the fatigue index error  $\Delta FI$  stated in table 5 the best results are achieved by using Dang Van and Matake criteria. The good results have been reached using Papuga PCr method as well. The next has been the Conjugated strength criterion (Fuxa) and other criteria.

## Acknowledgements

The paper was created under support of GACR, project no: 101/08/P141.

## References

- [1] Fuxa, J., Fojtík, F., Kubala, R., Torque machine fit for high cycle fatigue of material testing, *Experimental Stress Analysis*, Hotel Výchledy, 2007.
- [2] Fuxa, J., Kubala, R., Fojtík, F., Idea of Conjugated Strength Criterion, *Acta Mechanica Slovaca*, Vol. 1, 2006, p. 125–130.
- [3] Fojtík, F., Fuxa, J., The multiaxial material fatigue under the combined loading with mean stress in three dimension, *Applied and Computational Mechanics*, Vol. 3, 2009, p. 267–274.
- [4] Crossland, B., Effect of large hydrostatic pressure on the torsional fatigue strength of an alloy steel, In: *Proc. Int. Conf. on Fatigue of Metals*, Institution of Mechanical Engineers, London, 1956, p. 138–149.
- [5] Sines, G., Behavior of metals under complex static and alternating stresses, In: *Metal Fatigue*. Red. G. Sines a J. L. Waisman, New York, McGraw Hill 1959, p. 145–469.
- [6] McDiarmid, D. L., A general criterion for high cycle multiaxial fatigue failure, *Fatigue Fract. Engng. Mater. Struct.*, 14, 1991, No. 4, p. 429–453.
- [7] Papadopoulos, I. V., Davoli, P., Gorla, C., Filippini, M., Bernasconi, A., A comparative study of multiaxial high-cycle fatigue criteria for metals, *Int. J. Fatigue* 19, 1997, No. 3, p. 219–235.
- [8] Papuga, J., Růžička, M., Two new multiaxial criteria for high cycle fatigue computation, *Int. J. Fatigue* 30, 2008, No. 1, p. 58–66.
- [9] Papuga, J., Španiel, M., PragTic Fatigue Freeware and FatLim Databáze, *MECCA*, Vol. 5 (2007), No. 3.