

## Investigation and Diagnostic of Magnetic Control of Cryogenic Heat Pipes

F. Čingroš, J. Kuba

Katedra elektrotechnologie, Fakulta elektrotechnická, ČVUT v Praze,  
Technická 2, Praha

E-mail : cingrfil@fel.cvut.cz, kuba@fel.cvut.cz

### **Anotace:**

Tento článek se zabývá výzkumem a diagnostikou speciální regulační metody pro tepelné trubice. Bylo experimentálně zjištěno, že transport tepla v tepelných trubicích lze za určitých podmínek výrazně ovlivnit pomocí vnějšího statického magnetického pole. K tomu je nezbytně nutné, aby uvnitř tepelné trubice byla pracovní látka s výraznými magnetickými vlastnostmi, která navíc splňuje požadavky na specifické pracovní podmínky tepelné trubice. Jednou z mála takových látek je čistý kyslík, který se již dříve osvědčil v gravitační tepelní trubici řízené magnetickým polem. Nyní bylo zkoumání rozšířeno na kapilární tepelné trubice, které jsou směrově nezávislé. Byly provedeny experimenty se dvěma typy kapilárních soustav, přičemž bylo zkoumáno, jak se změní termodynamické vlastnosti tepelné trubice při expozici vnějším statickým magnetickým polem.

This paper deals with heat pipes controlled by a static magnetic field. In our previous work we have investigated possibilities of practical use of this method in several types of heat pipes. The major problem seems to be a suitable working fluid with sufficient magnetic properties. An excellent one is oxygen - a natural gas with exceptionally high magnetic susceptibility (in liquid state only). We have already tested a gravitational type of heat pipe filled with oxygen before. In this case excellent working and control possibilities were found out. Thus we have worked out the research of oxygen filled heat pipes, now with focus on types with a built in capillary structure (wick). Heat pipes with different capillary structures were made by this work and their working capabilities and control possibilities employing the magnetic field method were experimentally ascertained. Some results of the measurement are written in the text.

### **INTRODUCTION**

Heat pipes are excellent heat transport elements with extremely large effective thermal conductance (of about three magnitudes larger when compared with copper at standard water based heat pipe). Additionally they do not need any power supply and they are free of any moving parts. Thus heat pipes show high reliability and long life. Heat pipes are commonly used for cooling and heat transport in electronic devices, technological processes and in many other types of equipment as well.

From the technical point of view, heat pipe is an evacuated tube filled with a small amount of a working fluid (water, ethanol, nitrogen, sodium etc.). While heating one end of the tube (evaporator) the fluid inside boils and is vaporized. Vapor streams very fast through the tube and condensates on the wall at the colder opposite end (condenser). Return of the condensed liquid back to the evaporator is realized usually by the gravity (gravitational type) or using a wick (special capillary structure inside the heat pipe) and also in the wicked heat pipes gravity can assist.

In our research we are developing a new control technique of heat pipes based on exposition to a static magnetic field. In our previous experiments with a gravitational heat pipe filled with pure oxygen a significant influence of the static magnetic field on heat transport was observed.

Now we have realized similar experiments, but with a wicked heat pipe. Two types of the wick were tested - sintered and screen type. As a working fluid pure oxygen was employed again, because its magnetic properties in the liquid state are unique among all other natural liquids (only synthetic ferrofluids are comparable, but they have another important limitations). We have ascertained the influence of the static magnetic field on heat transport in the tested heat pipes. The results of the measurement are presented in the following text.

### **EXPERIMENTAL SETUP**

We have experimentally tested the magnetic field influence on heat transport in the heat pipes with various wicks - sintered and screen type. The experimental installation is shown in the Fig 1. As a working fluid pure oxygen was chosen because of its suitable magnetic properties. The magnetic susceptibility  $\chi$  of gaseous oxygen is  $2 \cdot 10^{-6}$  (at 300 K), but for liquid oxygen  $\chi = 300 \cdot 10^{-6}$  (at 50 K). This is enough to be possible to capture liquid oxygen by the static magnetic field. So the liquid flow in the wick might be restricted and it will cause a lower heat transport capability. Heat pipes with oxygen as a working fluid are able to work at very low temperatures only (from about 55 K to 105 K), so the tested heat pipes belong to a cryogenic range. The condenser had to be cooled by a

bath of liquid nitrogen ( $\text{LN}_2$  - 77 K) and the rest of the heat pipe was exposed to the forced convection of the room air (25 °C).

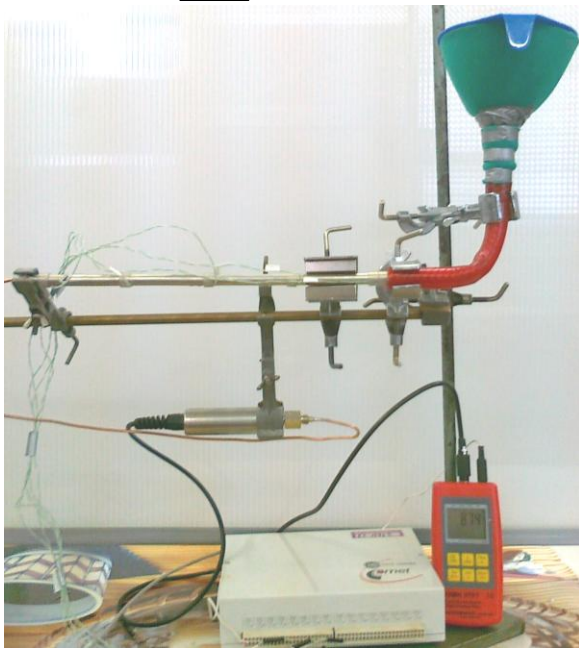
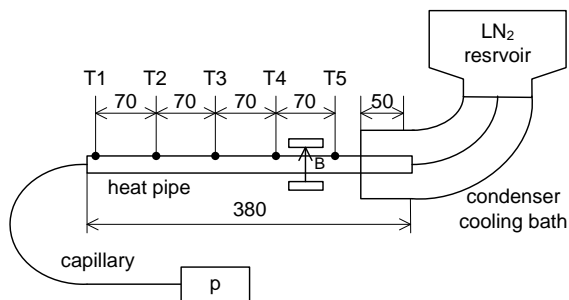

Fig. 1: Experimental installation schematically and in the real. A part of the heat pipe (between temp. points T4 and T5) was exposed to a static magnetic field, which should make a magnetic curtain for the liquid oxygen flow and influence the heat pipe capability. The heat pipe performance and working characteristics including the possible magnetic field effects were evaluated by measuring of temperature in five points along the heat pipe and by monitoring of pressure inside. The experiments were realized for various tilt angles of the heat pipe from the horizontal.

Two pieces of heat pipes were tested during this experiment. They were almost identical, different only in the wick type - sintered or screen. Both were made by a modification of standard water based heat pipes supplied by Thermacore, Inc. (made from a copper tube 380 mm long, outside diameter 10 mm and wall thickness 1 mm). The ends of the tube were compressively closed by copper plugs and copper capillaries were connected through the plugs to both ends of the heat pipe. Capillaries made a connection of the heat pipe with a filling device and with a manometer. The heat pipes were filled with pure

oxygen on the pressure 12,4 MPa at 25 °C (from the pressure vessel).

The static magnetic field was generated by two Nd-Fe-B permanent magnets (dimensions in millimeters - 40x20x10) with the magnetic circuit. The magnetic induction  $B$  was 0,5 T in the middle of the air-gap and the magnetic field was approximately homogeneous. The on/off regulation of the magnetic field affect was realized by positioning of the permanent magnets (to the heat pipe and away). The measurement of temperatures was realized by K-type thermocouples (calibrated for low temperatures by a Pt-thermometer) fixed in five points out on the heat pipe wall. The pressure was measured by a digital manometer connected to the heat pipe by the capillary. All the measured values were continuously monitored and recorded by a data logger.

## EXPERIMENTAL RESULTS

In the following results of above mentioned experiments are presented. We have measured working performance of the heat pipes with two types of wick - sintered and screen. The both tested types were measured at different tilt angles as seen in the Fig. 2. The following graphs present temperature characteristics measured in five points along the heat pipe (as seen in the Fig. 1), where the curves going in the graph from top to bottom belong to points from T<sub>1</sub> to T<sub>5</sub>. On the top of each graph time of magnetic field action is marked.

In the Fig. 3 there are temperature characteristics for the empty heat pipe without any working fluid. So in this case heat was transported only by thermal conductance of the copper container and the wick. Of course, no magnetic field action could be observed in this case. Comparing other graphs with this one contribution of the heat pipe operation can be seen.

In the horizontal position (Fig. 4, 6) the heat pipes operated only partially and they never became almost isothermal, as typical for the standard heat pipe operation. Their performance was limited by the insufficient wick operation. And because there was only a small (or even no one) liquid flow within, the magnetic field could not influence the thermal capability. However, at the screen type (in the Fig. 6) some small magnetic field action on the temperature characteristics can be remarked.

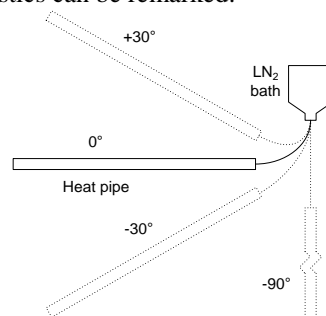

Fig. 2: Heat pipe positioning

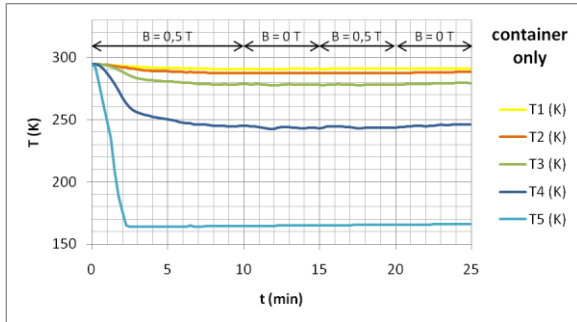

Fig. 3: Heat pipe without working fluid

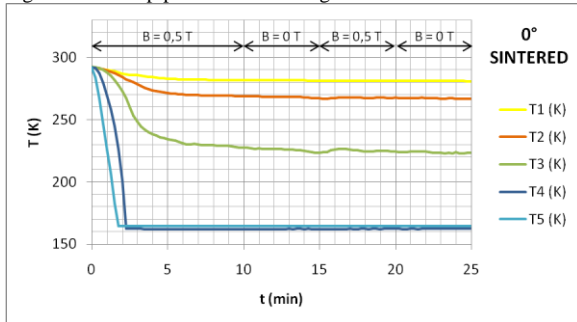

Fig. 4: Heat pipe with sinter wick in horizontal position

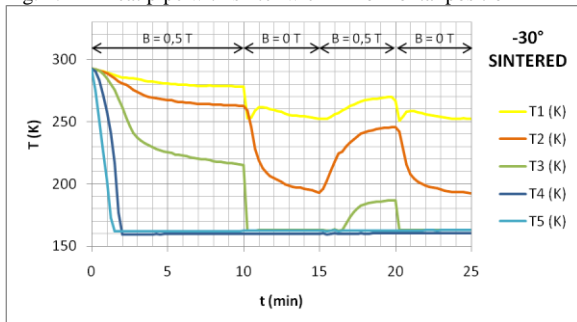

Fig. 5: Gravity assisted heat pipe with sinter wick

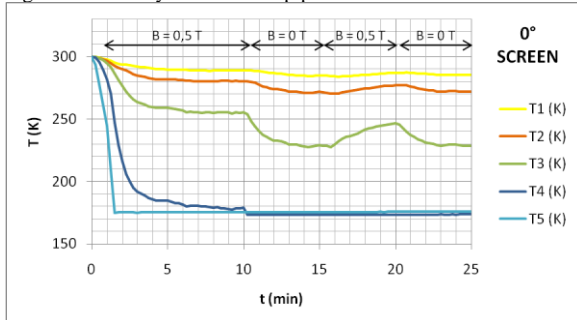

Fig. 6: Heat pipe with screen wick in horizontal position

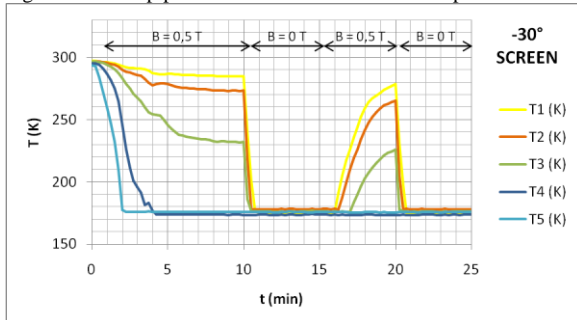

Fig. 7: Gravity assisted heat pipe with screen wick  
Other situation happened when the heat pipe was tilted down with the angle  $-30^\circ$  (Fig. 5, 7). Now gravity helped the wick to return the condensate to

the evaporator section and the standard operation mode was started. However, in the sintered one (Fig. 5) insufficiency of the working fluid caused by a large wick saturation is clearly seen (no isothermal state). The screen one heat pipe (Fig. 7) worked well in this case and became almost isothermal without the magnetic field exposition. Now, at the both wick types, the magnetic field influence on heat transport was significantly ascertained. The most dramatic effect was observed at the screen type, where the temperature  $T_1$  (at the end of the evaporator) varies in the range of about 110 K in dependence on the magnetic field exposition.

## CONCLUSIONS

In the realized experiments we have found out only poor wick capability at the both tested capillary structures and thus the heat pipes did not work at an adverse tilt angle. We assume it might be caused by a limited saturation of the wick and by some poor oxygen parameters which are important for the wick capability. Also horizontally the wick performance was not reliable. However, the screen one heat pipe seemed to partially work in this position. The return of the condensate was sufficient only in the gravity assisted mode.

Unfortunately, because of the partial wick failure the magnetic field control effect could be investigated only in part. The static magnetic field significantly affected heat flow mainly in the gravity assisted mode. Heat transport was dramatically restricted in this case and results of our previous experiments with gravitational heat pipes were verified. Some partial influence of the magnetic field was observed also in horizontal position at the screen one heat pipe. In other cases the adverse tilt angle disable the liquid flow in the wick and the magnetic field could not act on it.

This paper is based on the research program no. MSM 6840770012 “Transdisciplinary Research in the Area of Biomedical Engineering II” of the CTU in Prague and the student grant SGS 2011 no. OHK3-015/11 “Magnetic Field Effects on Special Thermal Systems” of the CTU in Prague.

## REFERENCES

- [1] F. Cingroš, T. Hron, “Working Fluid Quantity Effect on Magnetic Field Control of Heat Pipes”, *Acta Polytechnica*, vol. 9, 2009.
- [2] F. Cingroš, T. Hron, J. Kuba, “Magnetic Field Control of Cryogenic Heat Pipes”, In *ISSE conference proceedings*, Brno, 2009.
- [3] F. Cingroš, T. Hron, J. Kuba, “Vliv magnetického pole na transport tepla”, In *Diagnostika conference proceedings*, Nečtiny, 2007.